

## EM530 – 560C Magnetic Lock Wiring Instructions

### Magnetic Lock Wiring Instruction

#### A. 12VDC Input:

Connect the ground(-)lead from a 12VDC power source to black wire of PCB.  
 Connect the Positive(+)lead from a 12VDC power source to red wire of PCB.  
 Set jumper for 12VDC operation.

#### B. 24VDC Input:

Connect the ground (-)lead from a 24VDC power source to black wire of PCB.  
 Connect the positive (+)lead from a 24VDC power source to red wire of PCB.  
 Set jumper for 24VDC operation.

### Printed Circuit Board Schematic

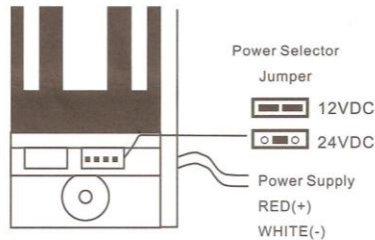

#### Important : Please Read Before Attempting To Install Magnetic Lock

- Handle the equipment with care, damaging the mating surfaces of the magnet or armature plate may reduce locking efficiency.
- The magnet mounts rigidly to the door frame. The armature plate mounts to the door with hardware. Kit provided that allows it to pivot about its center to compensate for door wear and misalignment.
- Template use must take place with the door in its normally closed position.
- Before installing , please add the thread locker to all screws.  
 Firmly tighten the screws to avoid fastening loosen.

#### Typical Installation:

##### A: MORTISE MOUNTED

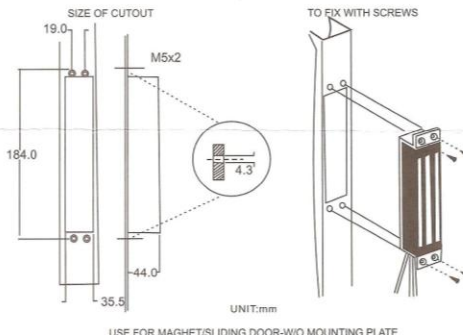
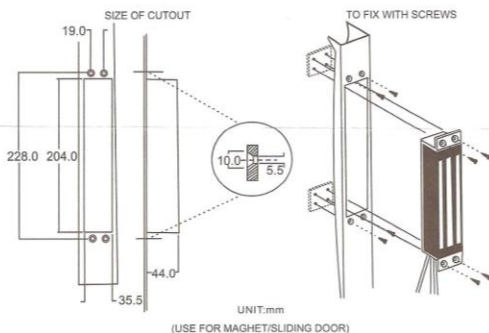
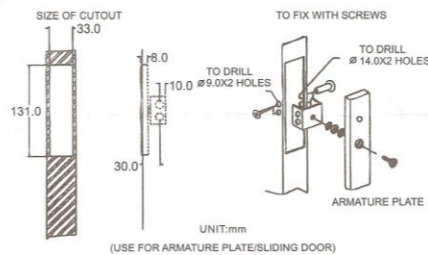

### B: SURFACE MOUNTED

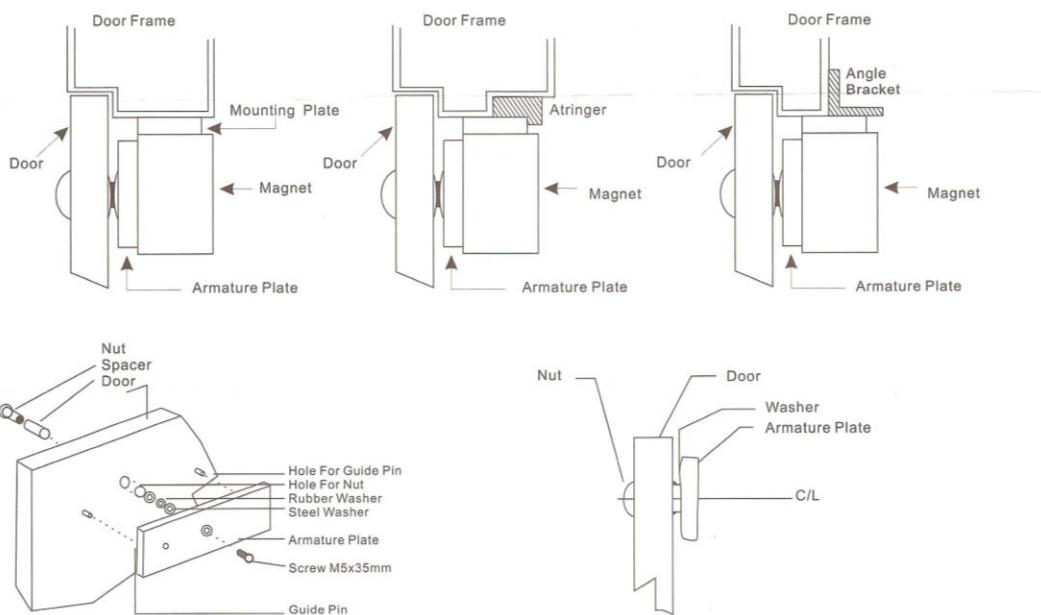

(USE FOR ARMATURE PLATE/SUPFACE MOUNTED)

**\*\*Important:** Fix the armature plate not too tightly, and make the rubber washer more flexible, in order to make the armature plate automatically adjust its proper position with the magnet.

## MOUNTING INSTRUCTION

### STEP 1

- FOLD TEMPLATE ALONG DOTTED LINE.
- PLACE TEMPLATE AGAINST DOOR AND HEAD FRAME.
- DRILL HOLES AS INDICATED ON TEMPLATE.

### STEP 2

- MOUNT THE ARMATURE PLATE TO DOOR USING 1 RUBBER WASHER SANDWICHED BETWEEN 2 STEEL WASHER (THE RUBBER WASHER AND 2 STEEL WASHER ARE INSTALLED ON THE THROUGH SEXNUT BETWEEN THE ARMATURE PLATE AND DOOR).

### STEP 3

- INSTALL THE MOUNTING PLATE
- ADJUST THE MOUNTING PLATE SO THAT IT AND THE ARMATURTE PLATE FORM A RIGHT ANGLE.
- USING THE MOUNTING PLATE AS A TEMPLATE, DRILL THE WIRE HOLE.
- DRILL AND INSTALL THE REMAINING MOUNTING SCREWS.

### STEP 4

- INSTALL MAGNET TO MOUNTING PLATE WITH 1 M4 SCREWS SUPPLIED.

### STEP 5

- INSTALL ELECTRICAL WIRING PER INSTRUCTION SHEET.

### STEP 6

- TEST ALL FUNCTIONS OF THIS MODEL (SEE WIRING INSTRUCTION).

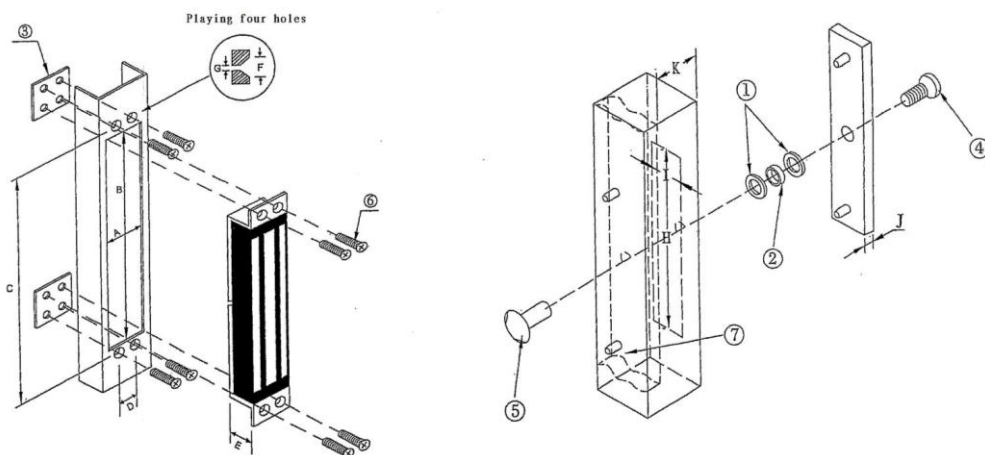

See on the map  
measurement: mm

	A	B	C	D	E	F	G
280M	39	180	206	19	28	9.5	4.5
	H	I	J	K			
280M	158	39	12	25			